



McGRORYGLASS **FIRE-RATED**

AGC Vision Line I20 by McGrory | Butt-Glazed Wall System Two Hour Fire-Resistive Frameless Assembly

AGC Vision Line I20 by McGrory is a butt-glazed, fire-rated system for interior, 2-hour transparent walls utilizing Pyrobel® I20, a low-iron and impact-safety fire-resistant glass. Tested and rated without the requirement of bulky or expensive framing, the system can be rapidly deployed while meeting aesthetic and budgetary requirements.

AGC Vision Line I20 by McGrory Features

- ♥ 120-Minute, 250°F temperature rise transparent wall system
- ♥ Continuous walls with an unlimited number of glass panels with sizes up to 40" x 114" or 114" x 40" (4560in²)*
- ♥ Narrow 4mm vertical joints for maximum transparency
- ♥ Low-iron, multi-ply laminated glazing with 84% visible light transmission and 48 STC

NOTE: AGC Vision Line I20 by McGrory complies with ASTM E119, UL 263, and CAN/ULC S101 fire-resistive standards.



Photo © AGC Glass Europe

Mid-Atlantic Corporate Center | 1400 Grandview Avenue | Paulsboro, NJ 08066
856.579.3200 (Ph) 856.579.3233 (fx) sales@mcgrory.com
www.mcgrory.com



McGRORYGLASS FIRE-RATED

AGC Vision Line I20 by McGrory | Butt-Glazed Wall System Two Hour Fire-Resistive Frameless Assembly

GLAZING DETAIL

Fire-Resistive Non-Bearing Wall – 120 Minute Rating

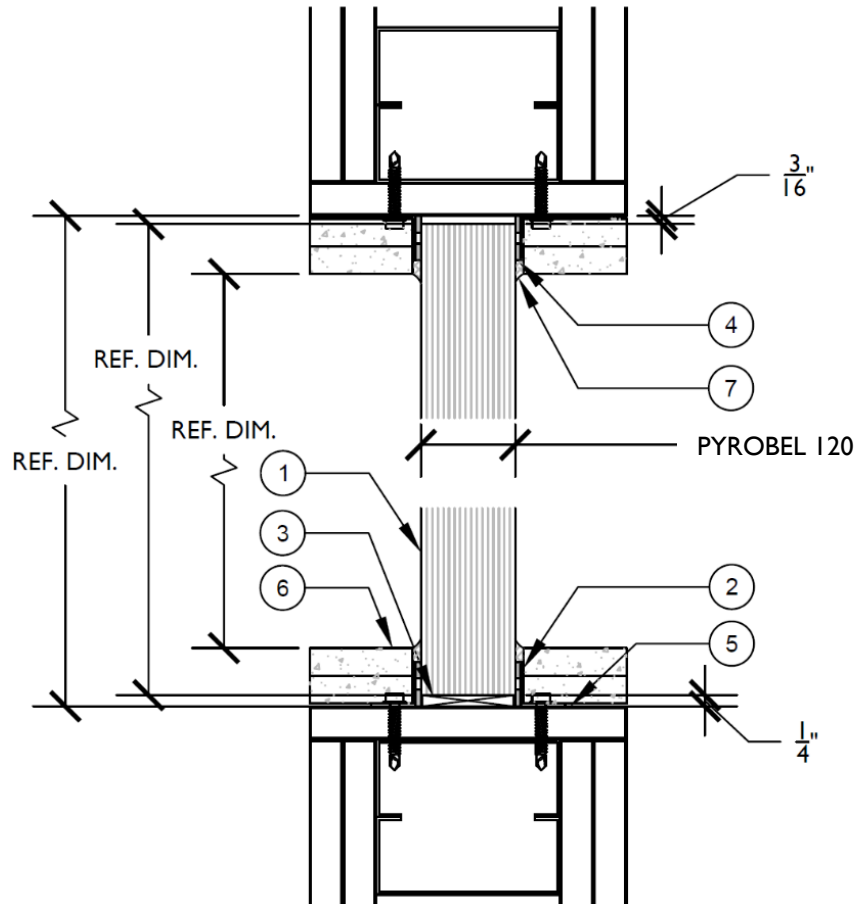

1. FIRE RESISTANT GLAZING MATERIAL - Pyrobel I20-53N or I20-53NEG by McGrory Glass.

Multi-ply, low-iron laminated glass totaling a thickness of 53 – 57mm (+/- 3mm), glazed into non-load bearing fire-rated wall construction.

2. GLAZING STOPS – Steel L-Angle Perimeter Channel. Minimum 1" wide x 1" tall x 1/8" thick steel angle, anchored with minimum #6 x 1" fasteners spaced 8" on center, starting 2" from each end. Stops may be discontinuous/spliced; butt-joints of stops must be offset from the butt-joints of the glazing panels by minimum of 6".

3. SETTING BLOCKS – Calcium Silicate. Minimum of (2) 1" wide x 1/4" tall x 3" long setting blocks per glazing panel; each located at the quarter point.



McGRORYGLASS FIRE-RATED

AGC Vision Line I20 by McGrory | Butt-Glazed Wall System Two Hour Fire-Resistive Frameless Assembly

4. GLAZING TAPE – Close Cell PVC. Minimum 1/8" thickness. Applied to glazing stop with either single strip or two (2) 1/2" strips applied for total 1" width of tape covering the glass-side of the stop.

5. WALL CONSTRUCTION – Gypsum/Studded or Masonry Fire-Rated Wall. Gypsum Association File # WP 1206 or any similar 1 hr fire-rated wall design with steel stud and track or wood stud wall with 1 layer on 5/8" sheetrock on each face. Rough opening must be double studded. Masonry walls of equal rating are permitted.

6. STOP COVER – Gypsum Wallboard. Two layers of minimum 1/2" thick, type C or X. Affixed by 2-1/2" drywall screws or fire-rated adhesive. Optional: Stop covers may be concealed with a decorative finish with a flash point greater than 400°F.

7. SILICONE SEALANT – 100% Neutral-Cure Silicone. Silicone bead applied at seam between stop cover and glass, continuously applied around perimeter on both sides of the opening

Butt-Joint Detail

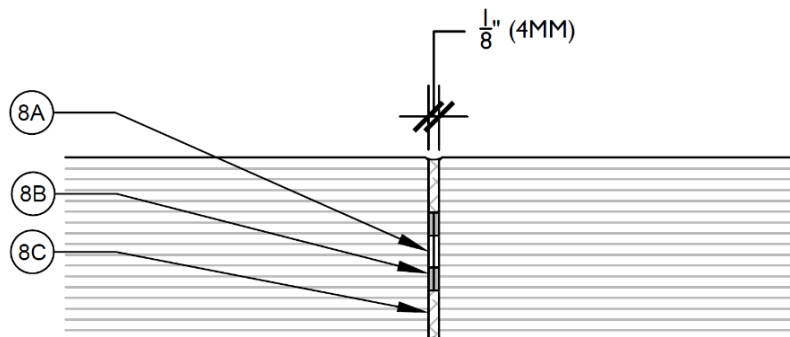

8a. GLAZING TAPE – Kerafix 2000/Superwool X607. Intumescent glazing tape, 4-5mm wide x 3mm thick (uncompressed). Single strip affixed to center of butt-joint prepped edge.

8b. GLAZING TAPE – Kerafix FXL 200. Intumescent glazing tape, maximum 10mm wide x 2mm thick. Affixed adjacent to both sides of item 8a.

8c. SILICONE SEALANT – DOWSIL 795 or Firestop 700. 100% Neutral-cure silicone glazing infill compatible with AGC Pyrobel.

Note: Glazing panels cannot be stacked one on top of another.

Note: Glazing panels are not to be considered a structural support for the fire rated wall.

*Installation design may vary depending on the size of panel(s) required for project.